



ELECTRONIC HID

PRODUCT OVERVIEW :

Bringing the comprehensive benefits of electronic HID technology to a broader range of market applications than ever before, Advance's low-profile e-Vision® electronic dimming ballast for 150-watt metal halide lamps delivers enhanced versatility and design flexibility to a wide spectrum of users. Ideal for a variety of downlighting and accent lighting applications, this ballast's 0-10V dimming interface and dimmability to 60% lamp power fully supports daylight harvesting and other sustainable design strategies. Its beneficial dimming feature, when integrated into building management systems, further permits reduced power consumption and reduced light levels during facility off-hours. In addition to driving superior lamp wattage regulation and significant energy savings over incandescent and magnetic HID alternatives, this ballast incorporates IntelliVolt® multiple-voltage technology as well as a range of enhanced safety features.

High-performing, long-lasting, and energy-efficient, Advance's e-Vision electronic dimming ballast for 150-watt metal halide lamps delivers an optimized lighting solution for the market's broad range of retail, institutional, office, and outdoor settings.



DESIGN HIGHLIGHTS:

- 0-10V dimming interface and dimmability to 60% lamp power
 - Supports daylight harvesting and sustainable design strategies
 - Supports energy-saving building management systems
- Compact and lightweight housing
 - Promotes enhanced versatility and design flexibility
- IntelliVolt® multiple-voltage technology (operates 120 to 277 volts, 50/60 Hz)
 - Enhances accuracy and ease of ordering and reduces stocking/SKU requirements
- Superior lamp wattage regulation
 - Optimizes lamp color quality over life
 - Reduces lamp-to-lamp variations
- Electronic circuitry
 - Drives significant energy savings relative to incandescent and magnetic HID alternatives
 - Enables ballasts to run cooler and operate quieter than many magnetic HID alternatives
 - Maximizes lamp life and minimizes re-lamping requirements, thereby reducing total cost of ownership relative to incandescent and magnetic HID alternatives
 - Further reduces material and labor costs by enabling the installation of up to 3½ more fixtures per circuit
- Automatic lamp power control, lamp monitoring, power control fault monitoring, output short circuit protection, lamp end-of-life (EOL) detection, and auto-reset thermal protection
 - Enhanced features ensure safety and minimize maintenance concerns
 - Lamp end of life detection safely removes power from the system upon lamp failure
- 85°C maximum case temperature rating
 - Ensures long life in demanding applications
- Cold-start capability down to -20°F
 - Ensures reliable operation in a wide range of extreme conditions

APPLICATIONS:

- **Retail**
- **Institutional**
- **Office**

Section 1 - Physical Characteristics

1.0 The electronic ballast shall be furnished with integral, color-coded leads.

Section II - Performance Requirements

- 2.0 The electronic ballast shall be IntelliVolt® and operate from a nominal line voltage range of 120-277 volts, +/-10%, 50/60 Hz.
- 2.1 The electronic ballast input current shall have Total Harmonic Distortion (THD) of less than 15%.
- 2.2 The electronic ballast shall have a Power Factor greater than 90%.
- 2.3 The electronic ballast shall have a lamp end-of-life detection and shutdown circuit.
- 2.4 The electronic ballast shall be Sound Rated A.
- 2.5 The electronic ballast output frequency to the lamps shall be less than 200 Hz to prevent acoustic resonance inside the lamp arc tube and to minimize visible flicker.
- 2.6 The electronic ballast shall provide a "Lamp Current Crest Factor" of less than 1.5.
- 2.7 The electronic ballast shall be thermally protected to shut off when operating temperatures reach unacceptable levels.

Section III - Regulatory Requirements

- 3.0 The electronic ballast shall meet the requirements of the Federal Communications Commission rules and regulations, Title 47 CFR part 18, for Non-Consumer equipment.
- 3.1 The electronic ballast shall be Underwriters Laboratories (UL) Listed and CSA Certified where applicable.

Section IV - Other

- 4.0 The electronic ballast shall not contain Polychlorinated Biphenyl (PCB's).
- 4.1 The electronic ballast shall carry a three-year warranty from the date of manufacture for operation at marked maximum case temperature or less.
- 4.2 The manufacturer shall have a twenty-five year history of producing HID lamp ballasts for the North American market.
- 4.3 The electronic ballast shall be produced in a factory certified to ISO 9002 Quality System Standards.

Installation Notes

- 1. Red lead must be connected to center terminal of lamp (for Edison screw base lamps). Do not connect red or blue lead to neutral or ground.
- 2. Use 4.0 kV pulse rated lamp holder. (Except where special lampholder is required, such as 22W Philips Mini MasterColor Lamp).
- 3. Maximum ballast-to-lamp distance is 5 ft. using typical wiring methods and materials. Additional distance up to 15 ft. may be possible using wire between lamp and ballast with a total measured capacitance of 100 picofarads or less. Consult Advance for application assistance.
- 4. Power mains must be cycled off and then on to reset ballast after failed lamps are replaced.

Ballast Hot Spot Location

Hot spot locations differ with each ballast model and are designated on the individual ballast labels. Consult ballast labels and ballast specification sheets for Hot Spot locations.

Lamp Data		Input Volts	Catalog Number	Certifications		Line Current (Amps)	Input Power ANSI (Watts)	Max. Case Temp.	Wiring Diag.	Fig.	Weight (lb)	Max. Distance to Lamp (ft)
Number	Watts			UL	CSA							
150 Watt Lamp, ANSI Code M102 or M142, Minimum Starting Temp. -30°C/-20°F												
1	150	120	IZTMH-150-C-LF (Leads exit either end)	✓	✓	1.4	169	85°C	6	C	2.5	5
		277		IZTMH-150-C-BLS (Leads exit bottom end)	✓							

Case Figure	Overall Length	Case Length	Case Width	Height	Mounting Length	Mounting Width
C	204mm [8.0"]	184mm [7.2"]	92mm [3.6"]	38mm [1.5"]	195mm [7.7"]	73mm [2.9"]

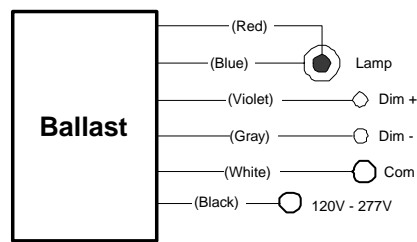

Ballast Case must be Grounded

Diag. 3

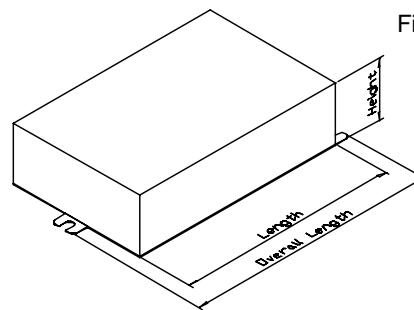

Fig. C

