



ELECTRONIC HID

PRODUCT OVERVIEW :

Lightweight and compact, Advance's e-Vision® Mini Square electronic ballasts for 39-watt and 70-watt metal halide lamps offer unprecedented design freedom and are ideal for a variety of downlighting, track lighting, and accent lighting applications. The ballasts feature Advance's exclusive IntelliVolt® multiple-voltage technology as well as all metallic enclosures (vs. plastic) for maximum performance and reliability. Electronic circuitry ensures superior lamp wattage regulation and power control over lamp life, while the ballasts' extensive array of protective features enhance safety and minimize maintenance concerns. The ballasts additionally feature a desirable 90°C maximum case temperature rating to ensure long life in the most demanding applications.

Versatile and energy-efficient, Advance's e-Vision Mini Square electronic ballasts for 39-watt and 70-watt metal halide lamps represent attractive, long-lasting, and cost-efficient alternatives to halogen and incandescent technology and enables a broad range of retail, commercial, and institutional users to enjoy the comprehensive benefits of electronic HID technology.

e-Vision®

Mini Square Electronic Ballast for 39-Watt and 70-Watt Metal Halide Lamps



DESIGN HIGHLIGHTS:

- Compact and lightweight housing (3.5" X 3.0" X 1.2") for both the 39-watt and 70-watt models
 - Promotes enhanced versatility and design flexibility
 - Ballast easily blends into modern fixture designs, supporting aesthetic objectives
- Superior lamp wattage regulation
 - Optimizes lamp color quality over life
 - Reduces lamp-to-lamp variations
- IntelliVolt® multiple-voltage technology (operates 120 to 277 volts, 50/60 Hz)
 - Enhances accuracy and ease of ordering and reduces stocking/SKU requirements
- HID technology lasts three times longer than halogen and up to five times longer than incandescent alternatives
 - Minimizes re-lamping requirements, reducing product and maintenance costs and optimizing total cost of system ownership
 - Represents a reliable, long-lasting, high-performing, and cost-effective alternative to incandescent and halogen technology
- Electronic circuitry
 - Drives significant energy savings relative to incandescent and magnetic HID alternatives
 - Enables ballasts to run cooler and operate quieter than many magnetic HID alternatives
 - Further reduces material and labor costs by enabling the installation of up to 3½ times more fixtures per circuit
- All metallic enclosures
 - Superior heat transfer relative to plastic, enhancing safety and durability
 - Meets universal code compliance
- Enhanced safety features include automatic lamp power control and lamp monitoring
 - Prevents lamp overpowering/thermal stress and ensures that the system shuts down should the lamp fail to ignite or exhibit erratic behavior
- Incorporation of lamp end-of-life (EOL) detection with an automatic ballast shutdown feature
 - Safely removes power from lamps when they reach end-of-life, enhancing safety and eliminating lamp cycling
- 90°C maximum case temperature rating
 - Ensures long life in high-temperature applications
- Cold-start capability down to -20°F (-30°C)
 - Ensures reliable operation in a wide range of extreme conditions

APPLICATIONS:

- Retail**
- Commercial**
- Institutional**
- Hospitality**

Section I - Physical Characteristics

1.0 The electronic ballast shall be furnished with integral, color-coded leads.

Section II - Performance Requirements

- 2.0 The electronic ballast shall operate from a nominal line voltage range of 120-277V, +/-10%, 50/60 Hz.
- 2.1 The electronic ballast input current shall have Total Harmonic Distortion (THD) of less than 15%.
- 2.2 The electronic ballast shall have a Power Factor greater than 90%.
- 2.3 The electronic ballast shall have a lamp end-of-life detection and shutdown circuit.
- 2.4 The electronic ballast shall be Sound Rated A.
- 2.5 The electronic ballast output frequency to the lamps shall be less than 200 Hz to prevent acoustic resonance inside the lamp arc tube and to minimize visible flicker.
- 2.6 The electronic ballast shall provide a "Lamp Current Crest Factor" of less than 1.5.
- 2.7 The electronic ballast shall be thermally protected to shut off when operating temperatures reach unacceptable levels.

Installation Notes

- 1. Red lead must be connected to center terminal of lamp (for Edison screw base lamps). Do not connect red or blue lead to neutral or ground.
- 2. Use 4.0 kV pulse rated lamp holder.
- 3. Maximum ballast-to-lamp distance is 6 ft (2m). using typical wiring methods and materials.
- 4. Power mains must be cycled off and then on to reset ballast after failed lamps are replaced.

Ballast Hot Spot Location

Hot spot locations differ with each ballast model and are designated on the individual ballast labels. Consult ballast labels and ballast specification sheets for Hot Spot locations.

Section III - Regulatory Requirements

- 3.0 The electronic ballast shall meet the requirements of the Federal Communications Commission rules and regulations, Title 47 CFR part 18, for Non-Consumer equipment.
- 3.1 The electronic ballast shall be Underwriters Laboratories (UL) Listed and GSA Certified where applicable.

Section IV - Other

- 4.0 The electronic ballast shall not contain Polychlorinated Biphenyl (PCB's).
- 4.1 The electronic ballast shall carry a three-year warranty from the date of manufacture for operation at marked maximum case temperature or less.
- 4.2 The manufacturer shall have a twenty-five year history of producing HID lamp ballasts for the North American market.
- 4.3 The electronic ballast shall be produced in a factory certified to ISO 9002 Quality System Standards.

Lamp Data		Input Volts	Catalog Number	Certifications		Line Current (Amps)	Input Power ANSI (Watts)	Max. Case Temp.	Wiring Diag.	Fig.	Weight (lb)	Max. Distance to Lamp (ft)
Number	Watts			UL	CSF							
39 Watt Lamp, ANSI Code M130, - M70 Watt Lamp, ANSI Code M98 or M143 or M139 Minimum Starting Temp. -30°C/-20°F												
1	39	120	IMH-39-G-LF or	✓	✓	0.39	46	90°C	3	G	0.9	5
		277	IMH-39-G-BLS	✓	✓	0.18	45					
1	70	120	IMH-70-G-LF or	✓	✓	0.67	80	90°C	3	G	0.9	5
		277	IMH-70-G-BLS	✓	✓	0.30	79					

LF = Side eads

BLS = Bottom leads and studs

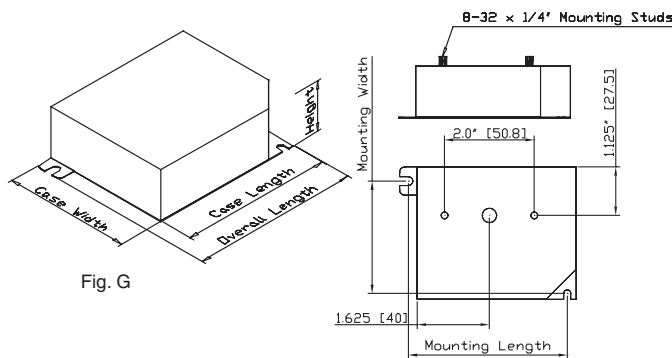

Case Figure	Overall Length	Case Length	Case Width	Height	Mounting Length	Mounting Width
G	97mm [3.8"]	90mm [3.5"]	77mm [3.0"]	30mm [1.2"]	87mm [3.4"]	67mm [2.6"]

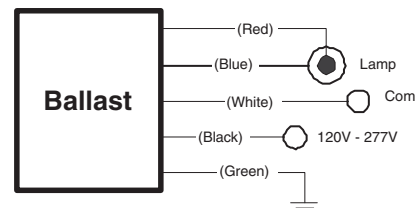

Diag. 3

Ballast Case must be Grounded