



Mini eHID ballast solutions

Philips Advance e-Vision® mini 20W, 22W and 39W electronic ballasts for metal halide lamps

With a low-profile design, our Philips Advance e-Vision 120V mini 20W, 22W and 39W electronic ballasts for metal halide lamps offer users all of the benefits of electronic HID technology in a compact housing that is perfect for use where track mounted 12V halogen transformers have traditionally been used. Featuring optimal thermal performance, these mini 20W, 22W and 39W metal halide ballasts are among the smallest in the industry. Ideal for a variety of downlighting, track lighting, and accent lighting applications, these ballasts feature various lead exit configurations for enhanced flexibility and ease of use. Their electronic circuitry provides superior lamp wattage regulation and power control over lamp life, while its extensive array of protective features enhances safety and minimizes maintenance concerns. Featuring a desirable 90° C maximum case temperature rating, our mini 20W, 22W and 39W e-Vision ballasts enable a long life for the most demanding retail, commercial and institutional applications.

Compact and lightweight housing (4.1" X 1.1" X 1.2")

- Promotes enhanced versatility and design flexibility, easily blending into modern luminaire designs while supporting the architect's aesthetic objectives

Energy efficient eHID technology lasts up to three times longer than halogen and up to five times longer than incandescent alternatives

- Minimizes re-lamping requirements, reducing product and maintenance costs and optimizing total cost of system ownership
- Represents a reliable, long-lasting, high-performing, and cost-effective lighting solution for down, track or accent lighting applications

Enhanced safety features include automatic lamp power control and lamp monitoring

- Reduction of lamp overpowering/thermal stress by shutting down should the lamp fail to ignite or behave erratically

Incorporation of lamp end-of-life (EOL) detection with an automatic ballast shutdown feature

- Removes power from lamps when they reach end-of-life, enhancing safety and preventing lamp cycling

PHILIPS
ADVANCE

Lamp Data		Input Volts	Catalog Number	Certifications		Line Current (Amps)	Input Power ANSI (Watts)	Max. Case Temp.	Wiring Diag.	Fig.	Weight (lb.)	Max. Distance to Lamp (ft.)
Number	Watts			UL	CSA							
20W Lamp, ANSI Code M156/C156 Minimum Starting Temp. -20°C/-4°F												
I	20	120	RMH-G20-K-LF RMH-G20-K-LFS	✓	✓	0.21	24	90° C	4	K	0.5	6
22W Lamp, ANSI Code M175/C175, Minimum Starting Temp. -20°C/-4°F												
I	22	120	RMH-20-K-LF RMH-20-K-LFS	✓	✓	0.23	26	90° C	4	K	0.4	6
39W Mini MasterColor Lamp, CDM-Tm 35W/930, ANSI Code M179 Minimum Starting Temp. -20°C/-4°F												
I	39	120	RMH-39-K-LF, RMH-39-K-BLS or RMH-39-K-LFS Note 1	✓	✓	0.40	45	90° C	4	K	0.5	6

I. Also operates 39W M130/C130 lamps

* Ordering information:

—LF Side exit leads with mounting feet (leads out opposite ends of the ballast)

—LFS Side exit leads with mounting feet (leads out same side of ballast)

—BLS Bottom exit leads with mounting studs

Case Figure	Overall Length	Case Length	Case Width	Height	Mounting Length	Mounting Width
K	119mm [4.4"]	104mm [4.1"]	33mm [1.1"]	30mm [1.2"]	114mm [4.5"]	13.5mm [0.5"]

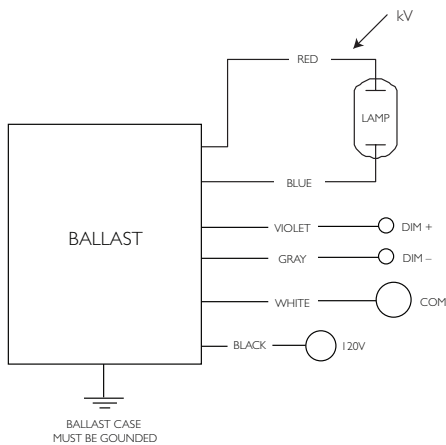

Diag. 4

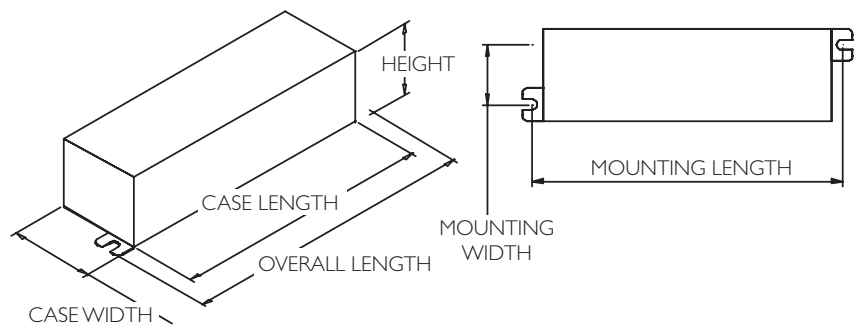

Fig. K

Ballast Specifications, Enclosure Dimensions, Lead Lengths and Wiring Diagrams

Section I - Physical Characteristics

- 1.0 The electronic ballast shall be furnished with integral, color-coded leads.

Section II - Performance Requirements

- 2.0 The electronic ballast shall operate from a nominal line voltage of 120 volts, +/-10%, 50/60 Hz.
- 2.1 The electronic ballast input current shall have Total Harmonic Distortion (THD) of less than 15%.
- 2.2 The electronic ballast shall have a Power Factor greater than 90%.
- 2.3 The electronic ballast shall have a lamp end-of-life detection and shutdown circuit.
- 2.4 The electronic ballast shall be Sound Rated A.
- 2.5 The electronic ballast output frequency to the lamps shall be less than 200 Hz to prevent acoustic resonance inside the lamp arc tube and to minimize visible flicker.
- 2.6 The electronic ballast shall provide a "Lamp Current Crest Factor" of less than 1.5.
- 2.7 The electronic ballast shall be thermally protected to shut off when operating temperatures reach unacceptable levels.

Section III - Regulatory Requirements

- 3.0 The electronic ballast shall meet the requirements of the Federal Communications Commission rules and regulations, Title 47 CFR part 18, for Non-Consumer equipment.
- 3.1 The electronic ballast shall be Underwriters Laboratories (UL) Listed and CSA Certified where applicable.

Section IV - Other

- 4.0 The electronic ballast shall not contain Polychlorinated Biphenyl (PCB's).
- 4.1 The electronic ballast shall carry a three-year warranty from the date of manufacture for operation at marked maximum case temperature or less.
- 4.2 The manufacturer shall have a twenty-five year history of producing HID lamp ballasts for the North American market.
- 4.3 The electronic ballast shall be produced in a factory certified to ISO 9002 Quality System Standards.

Ballast Hot Spot Location

See technical data sheet.

Installation Notes

1. Red lead must be connected to center terminal of lamp (for Edison screw base lamps). Do not connect red or blue lead to neutral or ground.
2. Use appropriately rated lamp holder.
3. Maximum ballast-to-lamp distance is 6 ft (2m) using typical wiring methods and materials.
4. Power mains must be cycled off and then on to reset ballast after failed lamps are replaced.



©2009 Philips Lighting Electronics
All rights reserved.

Form No. EH-5070-R03 12/09

Philips Lighting Electronics
10275 West Higgins Road
Rosemont IL 60018
Tel: 800-322-2086 Fax: 888-423-1882
Customer Support/Technical Service: 800-372-3331
OEM Support: 866-915-5886
www.philips.com/advance