



Smaller size, same great performance

Philips Advance high wattage compact core ballasts for metal halide lamps

Recognizing the HID luminaire manufacturers' need for size-efficient products, Philips Lighting Electronics N.A. offers a line of compact ballasts for high wattage metal halide applications. Utilizing the industry-standard core size normally used for 400 watt ballasts, these compact ballasts allow luminaire manufacturer's the opportunity to use the smaller, lighter weight 400 watt ballast housings in place of the larger housings normally associated with these higher wattage lamps. With full light output and reliable lamp starting, these CWA ballasts maintain the same UL bench-top temperature codes as their larger counterparts.

Ballasts deliver great performance in smaller profile

- 4 X 4 design that matches or exceeds performance of 4 X 6 counterparts
- Fully compliant with ANSI, UL and CSA standards

Meets standard temperature ratings and code requirements

- UL Class H, 180°C
- Advance Class N, 200°C

The compact core ballasts are available for all U.S. and Canadian voltages in two multi-tap formats

- 120/208/240/277 Quadri-volt®
- 347/480 dual-volt with 120V-output tap

PHILIPS
ADVANCE

Input Volts	Catalog † Number	Circuit Type	Watts Input	Max* Input Current	Nom Open Circuit Voltage	Fuse Rating (Amps)	Wiring Diag.	Dimensions			Non-PCB Capacitor				Total Weight (lbs)	Ignitor ††		UL Bench Top Rise Code 1029	
								Fig	A	B	Mfd	Min Volt	Cap Catalog Number	Dry or Oil		Part Number	Max Dist to Lamp (ft)	Class H (180C)	Philips Advance Class N (200C)
750 Watt Lamp, ANSI Code M149 (Pulse Start)																			
120/208 240/277	71A6490*	Super CWA	820	7.0/4.0/ 3.5/3.0	340	20/10/ 10/10	M	2	3.0	4.9	28	400	7C280S40	D	17.5	LI573-H5	10	D/D D/D	A/A A/A
347/480 120T	71A64F0-T*	Super CWA	820	2.5/1.7	340	7/5	M	2	3.0	4.9	28	400	7C280S40	D	17.5	LI573-H5	10	E/E	A/A
875 Watt Lamp, ANSI Code M166 (Pulse Start)																			
120/208 240/277	71A6498*	Super CWA	940	7.8/4.3/ 3.9/3.4	415	20/10/ 10/8	M	2	3.0	5.0	21	480	MD2100-030	○	17.5	LI572-H5★	5	E/E E/E	A/A A/A
347/480 120T	71A64F8-T*	Super CWA	945	2.8/2.0	415	7/5	M	2	3.0	5.0	21	480	MD2100-030	○	17.5	LI572-H5★	5	E/E	A/A
1000 Watt Lamp, ANSI Code M47																			
120/208 240/277	71A6590*	CWA	1070	9.0/5.2/ 4.5/3.9	415	20/15/ 10/10	A	2	3.4	5.3	24	480	MD2409-100	○	19.0	—	—	D/D D/D	A/A A/A
347/480 120T	71A65F0-T*	CWA	1070	3.1/2.2	415	8/6	A	2	3.4	5.3	24	480	MD2409-100	○	19.0	—	—	D/D	A/A
1000 Watt Lamp, ANSI Code M141 (Pulse Start)																			
120/208 240/277	71A6591*	Super CWA	1070	9.0/5.2/ 4.5/3.9	415	20/15/ 10/10	M	2	3.4	5.3	24	480	MD2409-100	○	19.0	LI572-H5★	5	D/D D/D	A/A A/A
347/480 120T	71A65F1-T*	Super CWA	1070	3.1/2.2	415	8/6	M	2	3.4	5.3	24	480	MD2409-100	○	19.0	LI572-H5★	5	D/D	A/A

† Ordering information - Contact your Philips Lighting Electronics N.A. representative for additional information.

• For CWA and SCWA circuits, figure is operating current.

†† Each ballast requiring an ignitor is furnished standard with the **Short Range** ignitor model shown for use within fixtures. If a **Long Range** ignitor is required for remote mounting, contact your Philips Lighting Electronics N.A. representative.

★ Equipped with an auto-reset thermal protector to prevent ignitor from overheating in the event of lamp failure.

* Dual rated Class H (180°C) / Advance Class N (200°C) insulation system.

Fig. 2 Core & Coil

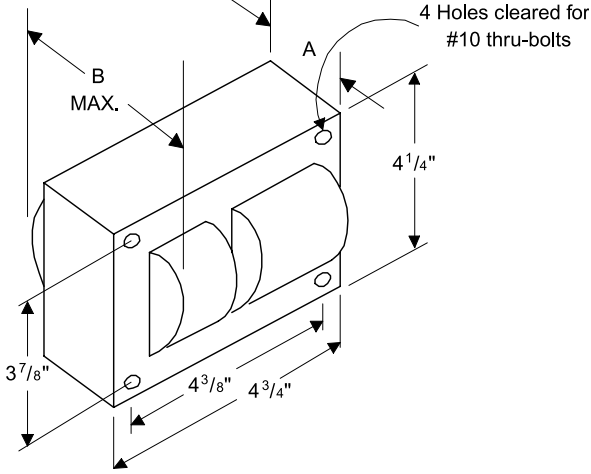

Metal Halide Core Size Comparison

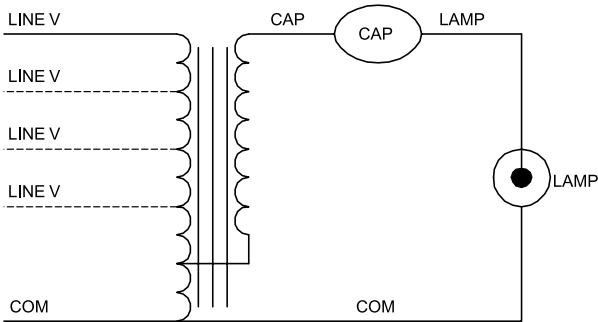
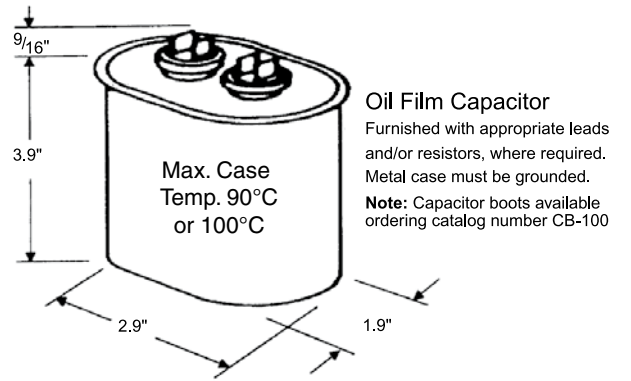
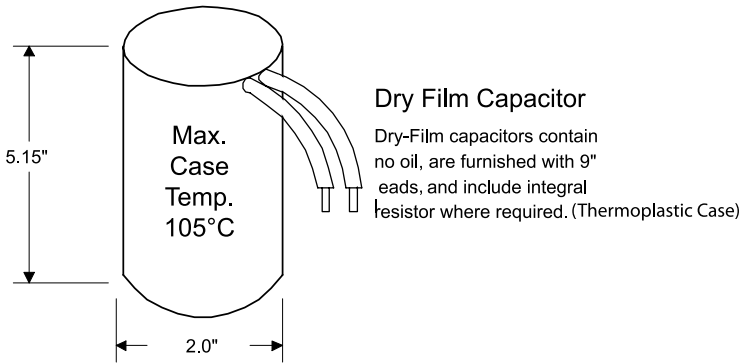
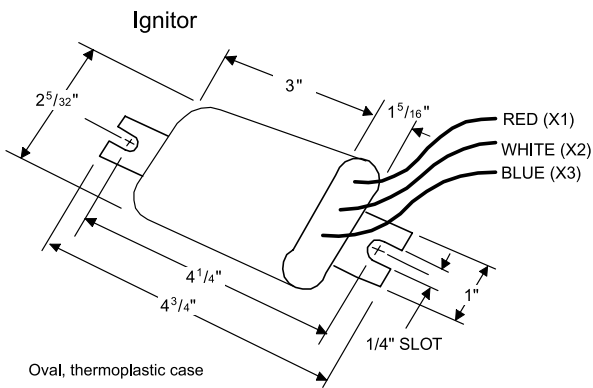
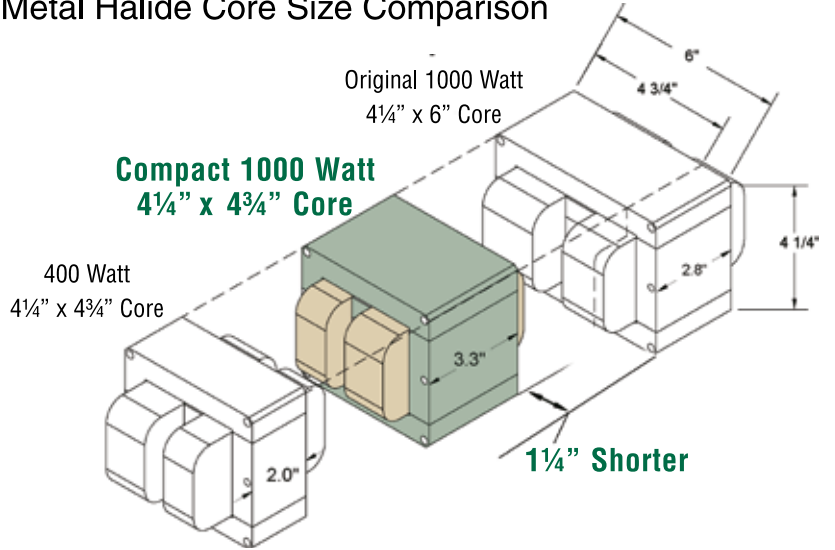

Fig. A

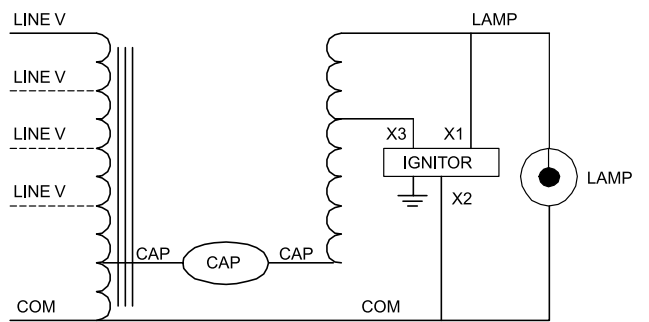

Fig. M



©2008 Philips Lighting Electronics N.A.
All rights reserved.

Form No. HI-4100-R03 11/08

Philips Lighting Electronics N.A.
10275 W. Higgins Road
Rosemont IL 60018
Tel: 800-322-2086 Fax: 888-423-1882
Customer Support/Technical Service: 800-372-3331
OEM Support: 866-915-5886
www.philips.com/advance